

EH Series

Turnkey Station With MV Transformer Integrated (String PCS, 1500V)

Features

- 200 kW/215kW fold expansion up to 4.3MW inside 20 ft structure
- Power Module easily replacement reduce repair time
- Achieve higher battery capacity utilization
- Allow expand new battery cluster to the old system
- Improve SOC imbalance between different battery racks
- Battery system achieve more deep DOD ability
- Built in Sub-Array Management Unit support IEEE 2030.5
- More easily to perform periodic battery calibration



Circuit Diagram

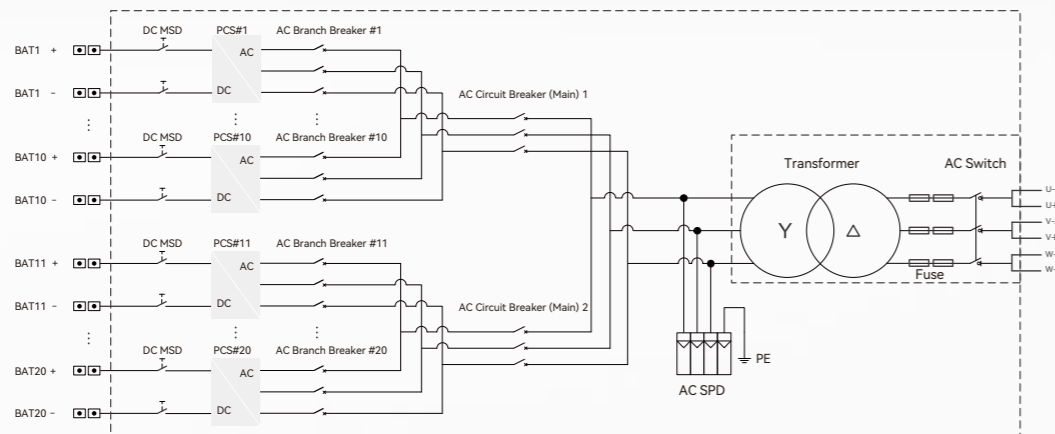

Model	EH-3200-HA-MR-US-34.5	EH-4000-HA-MR-US-34.5
DC parameters		
Max. DC voltage	1500V	
Max. DC current	224.5A*16	224.5A*20
Battery voltage range	1000 ~ 1500V	
Number of DC inputs	16 or 8	20 or 10
AC parameters (On-Grid)		
AC output power	220kVA*16@35°C, 200kVA*16@45°C, 180kVA*16@50°C 220kVA*20@35°C, 200kVA*20@45°C, 180kVA*20@50°C	
PCS Nominal AC voltage	690V, 3W+PE	
PCS AC voltage range	607~759V (Adjustable)	
PCS Max. AC output current	184.1A*16@35°C, 167.4A*16@45°C, 150.6A*16@50°C 184.1A*20@35°C, 167.4A*20@45°C, 150.6A*20@50°C	
Nominal grid frequency	60Hz	
Harmonic (THDi)	<1.5% (100% load)	
Power Factor	-1 ~ +1	
AC parameters (Off-Grid)		
PCS Nominal AC voltage	690V, 3W+PE	
PCS AC voltage range	607~759V (Adjustable)	
AC voltage distortion	<1.5% (100% linear balance load)	
DC voltage component	<0.5% Un (Linear balance load)	
Unbalanced load capacity	100%	
Nominal grid frequency	60Hz	
Transformer		
Isolation mode	Oil-Immersed Transformer	
Transformer rated power	3520kVA@35°C, 3200kVA@45°C, 2880kVA@50°C 4400kVA@35°C, 4000kVA@45°C, 3600kVA@50°C	
LV/MV voltage	0.69kV/34.5kV (11.8kV~34.5kV Optional)	
Transformer vector group	Dy1 or Dy11	
Transformer cooling type	KNAN	
Oil type	Degradable oil	
General data		
PCS Max. efficiency	98.80%	
PCS CEC efficiency	98.50%	
Ingress protection rating	TYPE 3R	
Operating temperature range	-40~+60°C (>45°C derating)	
Relative humidity	0~100% (no condensing)	
Max. altitude	1000m	
Cooling method	Forced air cooling	
Communication port	RS485/CAN/Ethernet	
Dimensions (W*D*H)	6058×2438×2896mm	
Weight	16000kg	17000kg